

**THE COMMONWEALTH OF MASSACHUSETTS  
FACILITIES PLANNING  
PHYSICAL PLANT BUILDING  
360 CAMPUS CENTER WAY  
UNIVERSITY OF MASSACHUSETTS  
AMHERST, MA 01003-9248  
10 January 2011**

**ADDENDUM #1**

Contract No: **UMA 11-20**

Project No.: # **08-00103001**

Account: **132542**

Title **Lincoln Campus Center Parking Office**

The attention of bidders submitting proposals for the above subject project is called to the following addendum to the specifications and drawings. The items set forth herein, whether of omission, addition, substitution, or clarifications are all to be included in and form a part of the proposal submitted.

THE NUMBER OF THIS ADDENDUM (1) MUST BE ENTERED IN THE APPROPRIATE SPACE 'B' PROVIDED AFTER THE WORD 'NUMBERED' ON PAGE E OF THE CONTRACT FORM ENTITLED 'FORM FOR GENERAL BID'

**Item 1; Drawing A-3 Main Counter, Elevations and Details**

- A. SK-1; attached are hereby included and are part of this addenda, all work show shall be incorporated in the contract.**

**Item 2: Drawing A-4 Ticket Counter, Elevations and Details**

- A. Cashiers Window Detail A and Detail at Section 5-5 change counter fascia indicated "stone face " to ¾" hardwood to the size indicated with the same profile.**

**By: John O. Martin Director**

**Procurement**

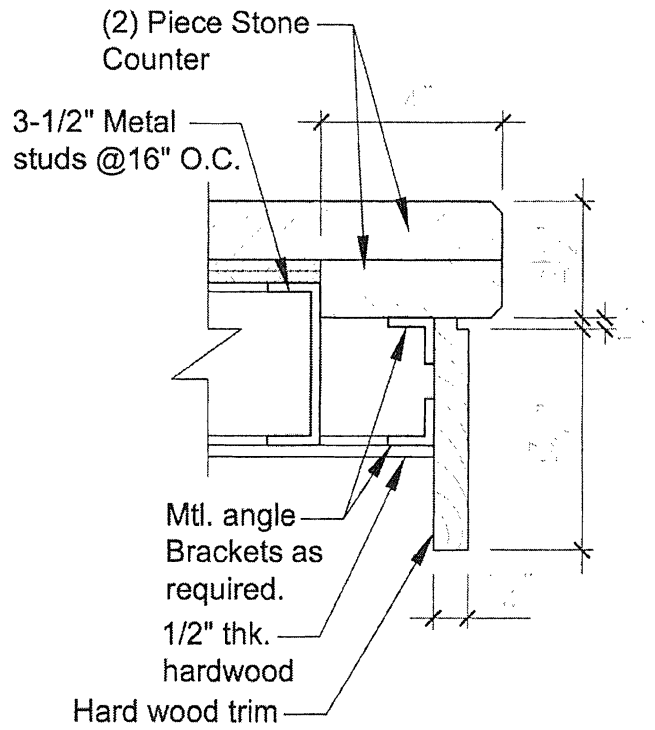

<b>SK-1</b>	DRAWING NO. A-413-08-001030	DRAWN BY: T.J.R. CHECKED BY: J.M. DESIGNED BY: J.M.	Lincoln Campus Center - Bldg. #413 Garage, Toilet Room Conversion Counter Edge Detail	UNIVERSITY OF MASSACHUSETTS AMHERST, MASSACHUSETTS	
	SCALE: 3" = 1'-0"	FACILITIES AND CAMPUS PLANNING A/E SERVICES UNIVERSITY OF MASSACHUSETTS 360 CAMPUS CENTER WAY AMHERST, MA 01003			
	DATE: 01/10/2011	(NCCC) 413.645.1383 (FAX) 413.542.3544			
PROJECT NO.: #08-001030		CONTRACT NO.: #			