



TectonArchitects inc

HARTFORD CONNECTICUT
860 548 0802
tectonarchitects.com

Notice:
This drawing is the property of Tecton Architects | Inc. The use, re-use or reproduction of this drawing for any purpose whatsoever without an expressed written agreement between Tecton Architects | Inc and the user is prohibited. Rights to use the information on this sheet are not transferred until payment has been received for services rendered. Any rights so granted are non-transferable to other parties without the prior expressed written consent of Tecton Architects | Inc

© 2010 Tecton Architects | Inc



GARCIA-GALUSKA-DESOUSA
CONSULTING ENGINEERS INC
370 Faunce Corner Road, Dartmouth, MA 02747-1271
508-998-5700 • FAX 508-998-0883 • E-MAIL info@g-g-d.com

Owner
TOWN OF WILBRAHAM

240 SPRINGFIELD STREET
WILBRAHAM, MA

Project
Wilbraham Fire Station

2770 Boston Road
Wilbraham, MA

Key Plan

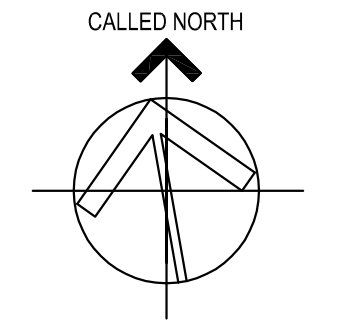

Seals
BID SET

Issues	
Date	Description

Revisions		
No.	Date	Description

Drawing Title
VIBRATION & SEISMIC II

Issue Date: 01/19/12

Project No: TA-01-01 Scale: NTS

Project Manager: JM Production Leader:

Project Architect: JB Peer Reviewer:

Drawing Number

VS-2

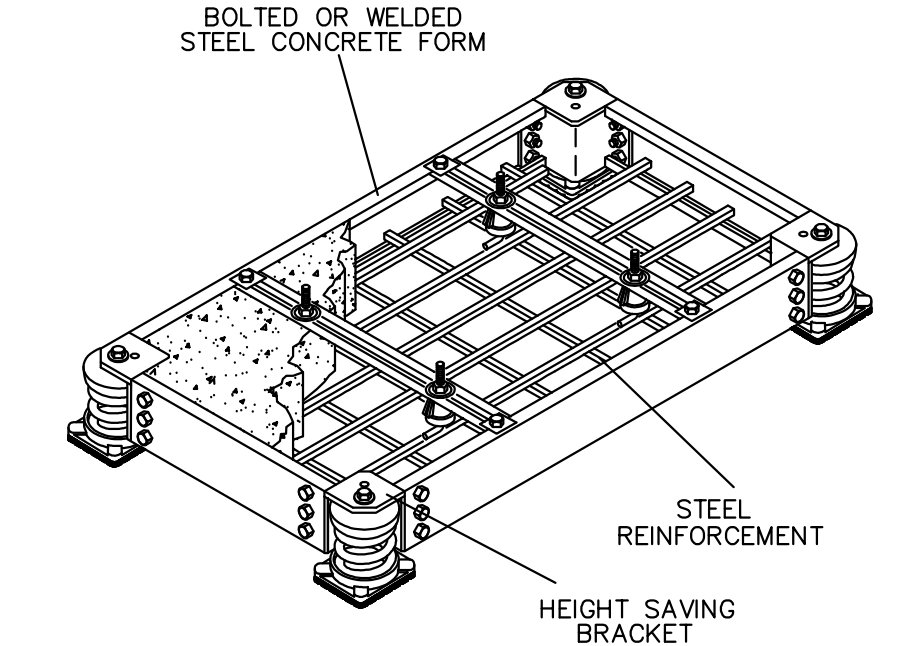

BMK CONCRETE FORM BASE SPECIFICATION 21

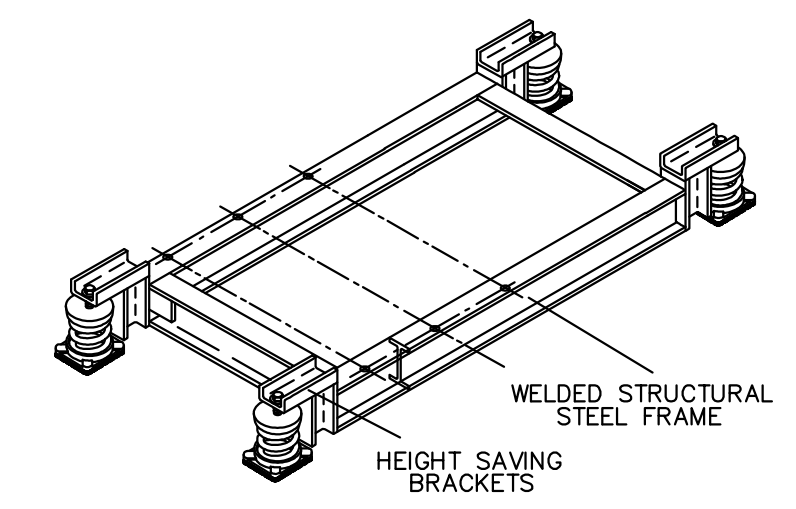

WF WIDE FLANGE STEEL BASE SPECIFICATION 20

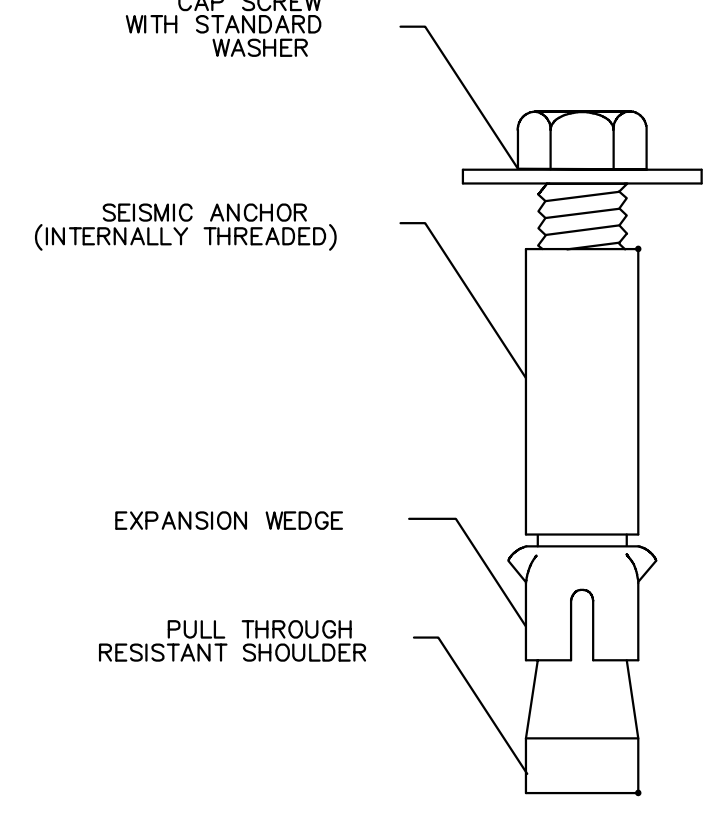

SAB SEISMIC ANCHOR BOLT SPECIFICATION 19

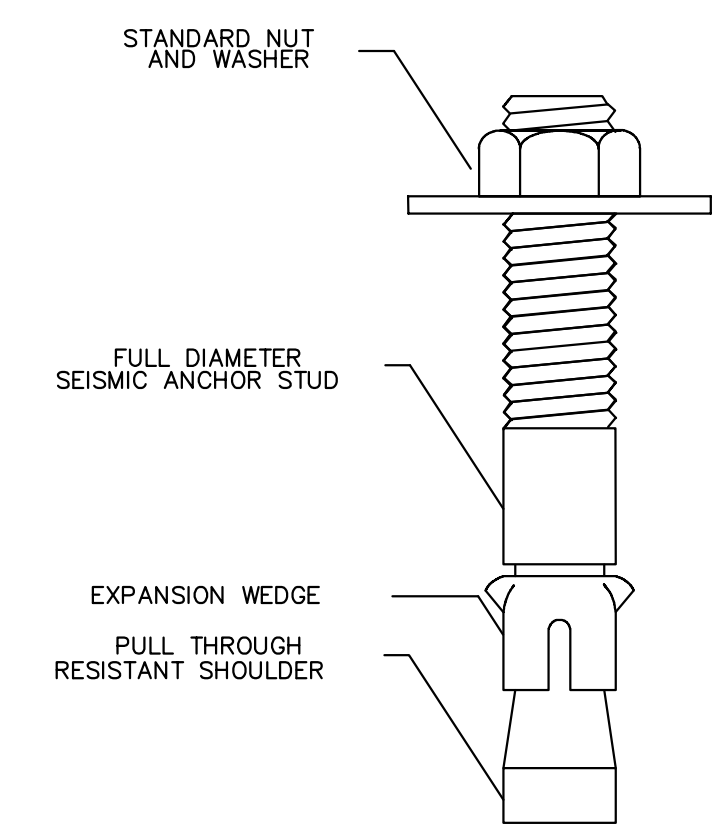

SAS SEISMIC ANCHOR STUD SPECIFICATION 18

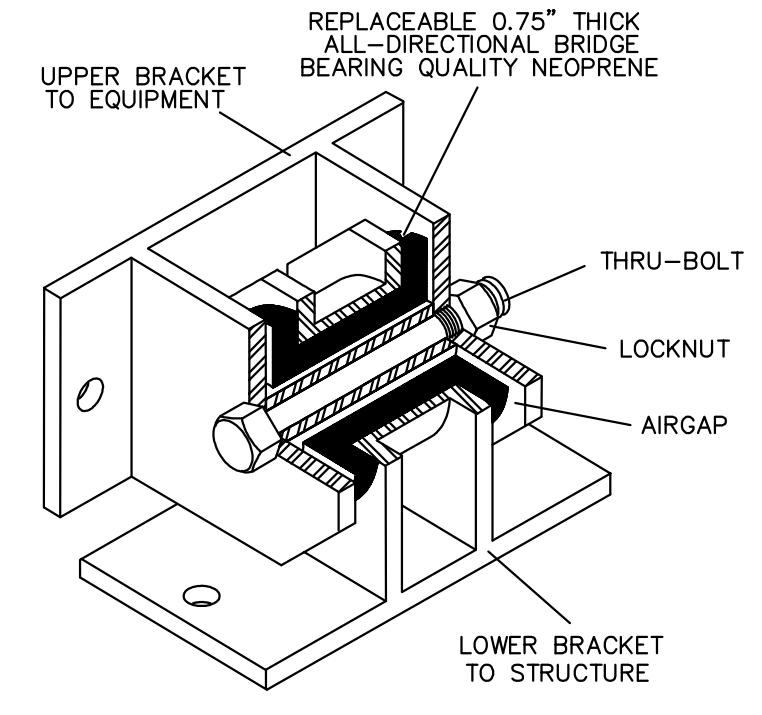

Z1011 ALL DIRECTIONAL SEISMIC SNUBBER SPECIFICATION 17

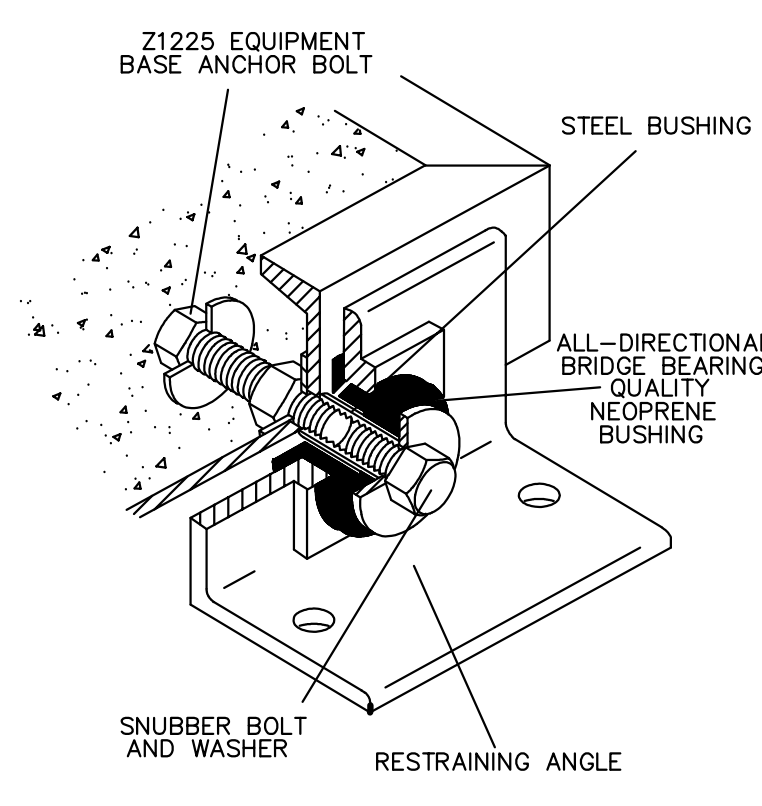

Z1225 ALL DIRECTIONAL SEISMIC SNUBBER SPECIFICATION 16

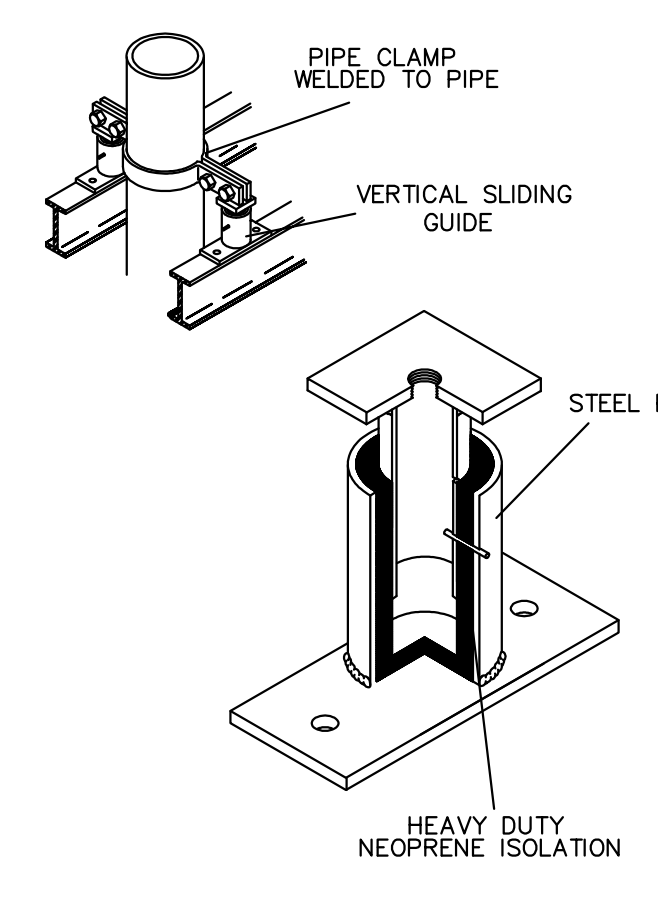

VSG VERTICAL SLIDING GUIDES SPECIFICATION 26

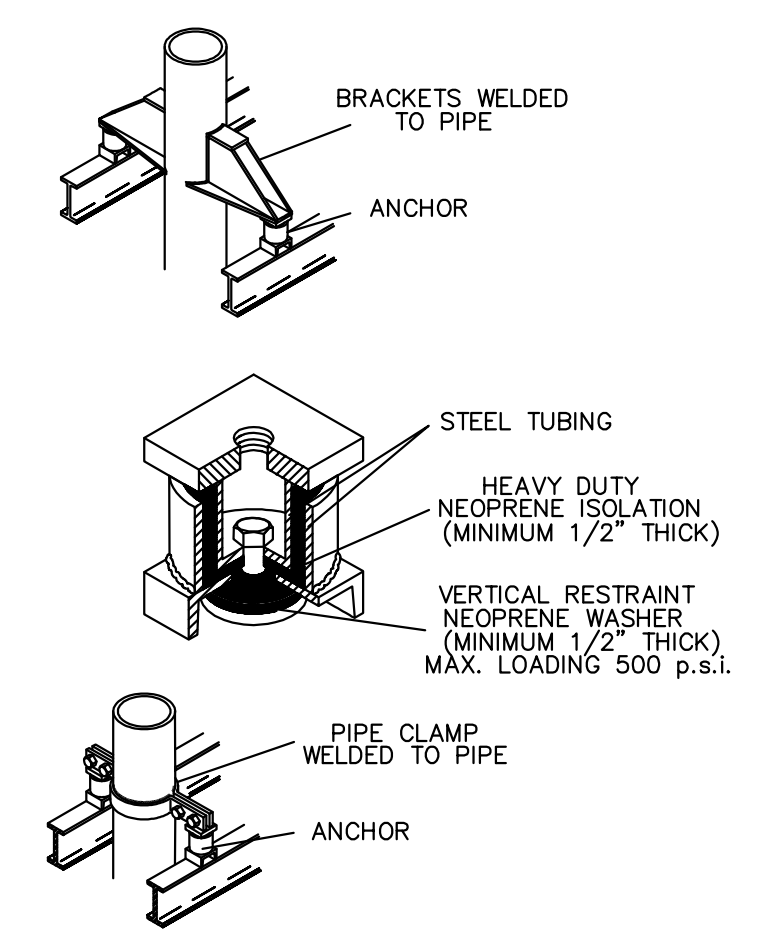

ADA ALL DIRECTIONAL ANCHOR SPECIFICATION 25

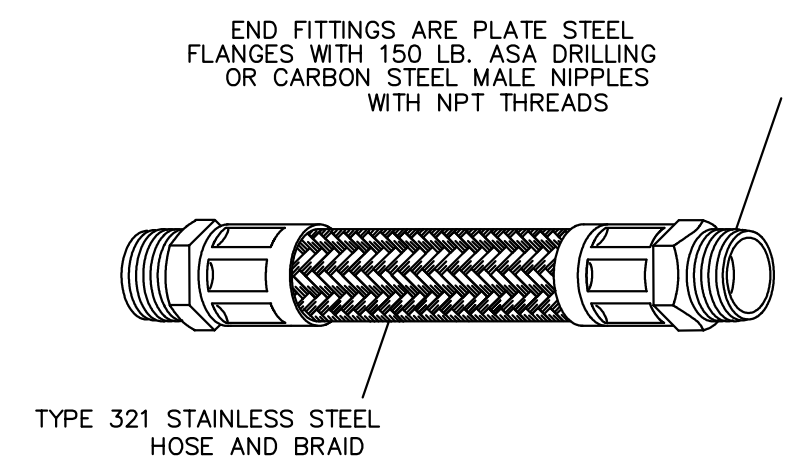

BSS STAINLESS STEEL HOSE SPECIFICATION 24

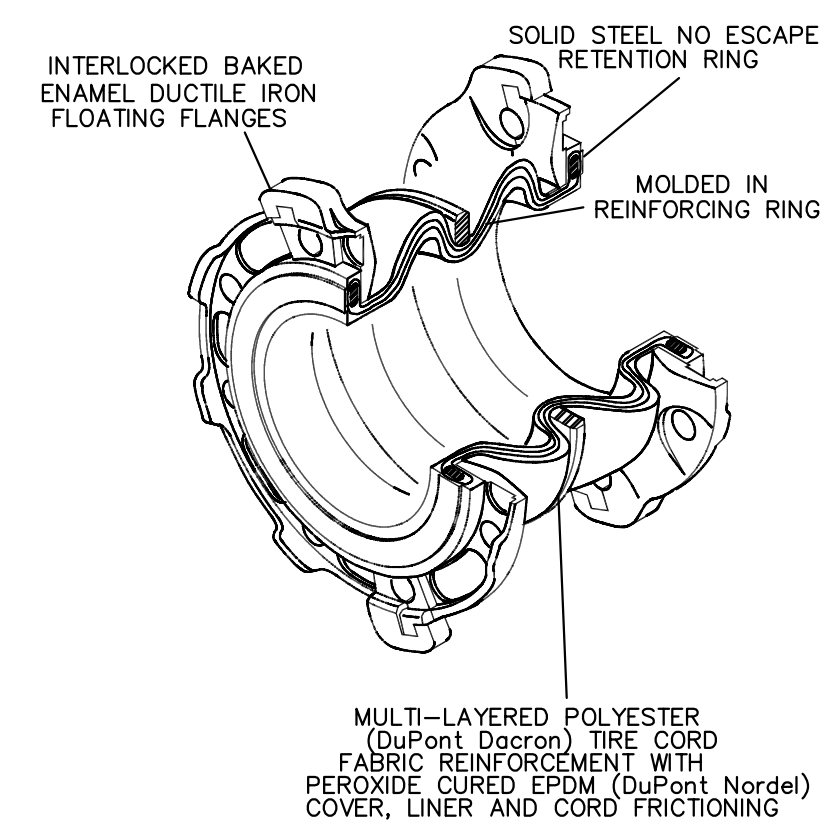

SFDEJ MOLDED EXPANSION JOINT SPECIFICATION 23

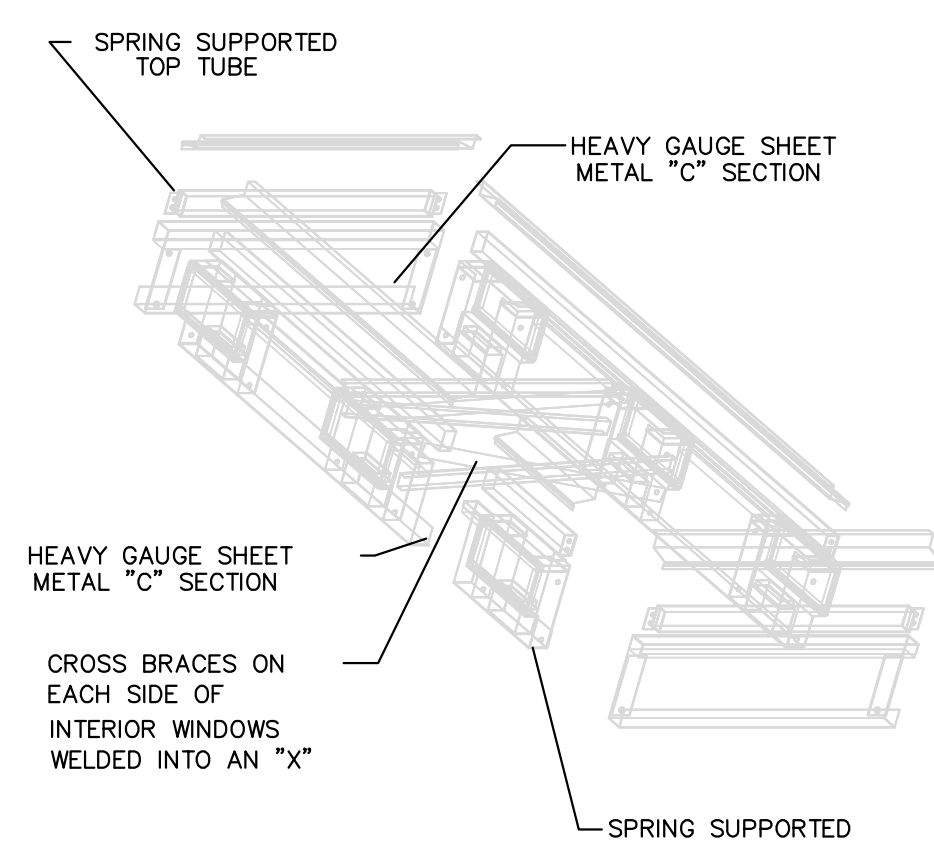

RSC SEISMIC ROOFTOP CURB SPECIFICATION 22

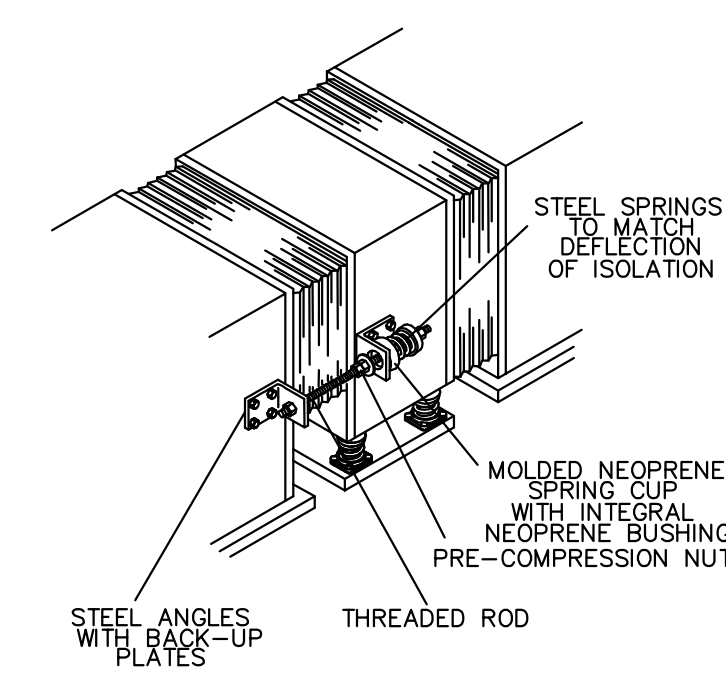

WB HORIZONTAL THRUST RESTRAINTS USED IN PAIRS SPECIFICATION 28

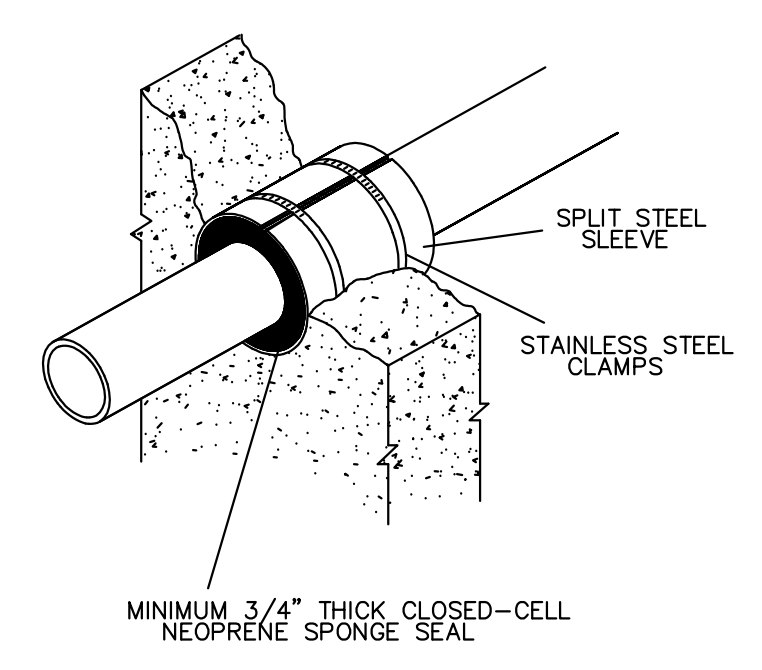

SWS ACOUSTICAL WALL, CEILING OR FLOOR SEAL SPECIFICATION 27